

CAD FILE :

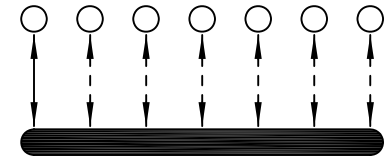

SCHMATIC (SHORTING)

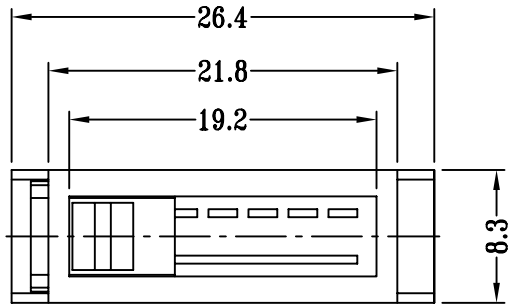
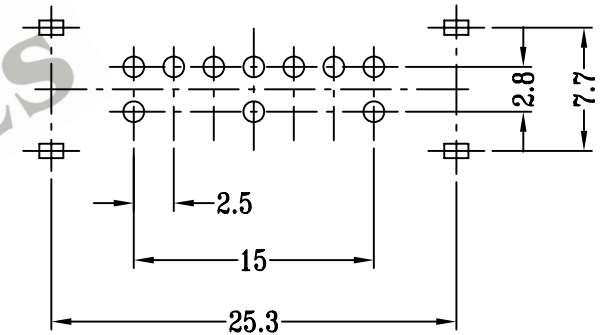
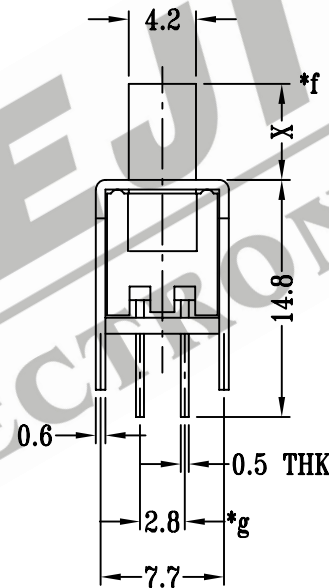
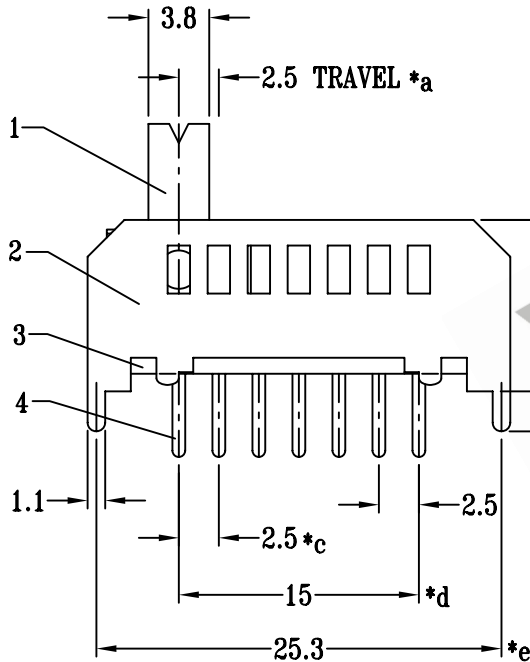

P.C.B LAYOUT

注:带"*"表示关键尺寸(7个)

8					TOLERANCE UNLESS SPECIFIED	SHENZHEN XIEJIA ELECTRONICS CO.,LTD.					
7	STEEL BALL	STEEL	2	NATURAL							
6	CONTACT CLIP	COPPER STRIP	1	Ag PLATED	WITHIN: 1.5±0.1mm OVER : 1.5±0.2mm	ISSUE	DATE	DESCRIPTONS		APPD	
5	SPRING	STEEL WIRE	2	TEMPER							
4	TERMINAL	BRASS STRIP	10	Ag PLATED OVER Ni PLATED	TITLE: VERTICAL SLIDE SWITCH		UNIT : M M		DRWG NO :XJ-DR-SS17E11-00		
3	TERMINAL BASE	PHENOLIC RESIN	1	NATURAL			MODEL: SS-17E11		SCALE : 2:1		DWN.
2	FRAME	STEEL STRIP	1	ZINC PLATED	ALL MATERIALS MUST BE COMPLIANT TO ROHS				CHK'D		FANGYING
1	KNOB	POM	1	BLACK			APPD.		KANGXINAN		2003-12-19
NO.	PART NAME	MATERIAL	QTY.	FINISHING							